

Y-Circ P-COAX

REV.001.1

ASSEMBLY INSTRUCTIONS MONTAGEANLEITUNG

FEMALE
MALE



01 Strip the coax cable as describe
Coax-Kabel wie beschrieben abisolieren

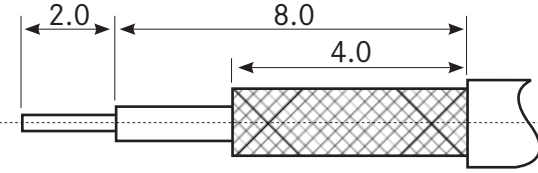

02 Slide the Crimp ferule on the cable
Crimphülse auf das Kabel schieben

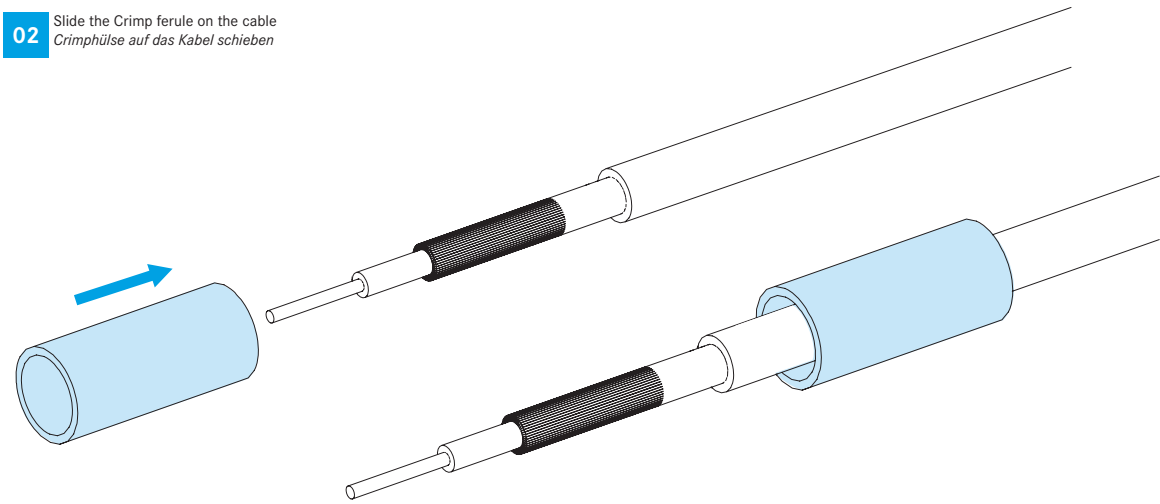

03 Insert the inner conductor into the contact and solder it
Innenleiter in Kontakt einführen und verlöten

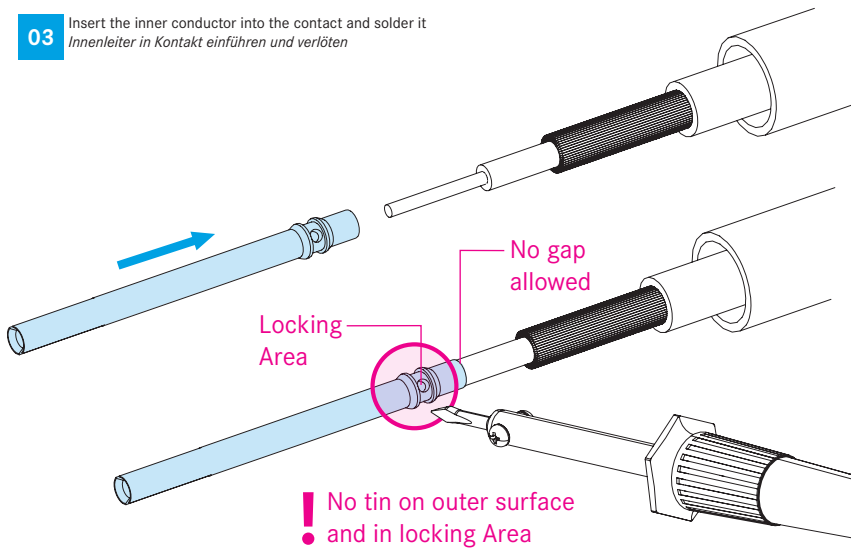

04 Pull shielding back
Schirmgeflecht zurück schieben

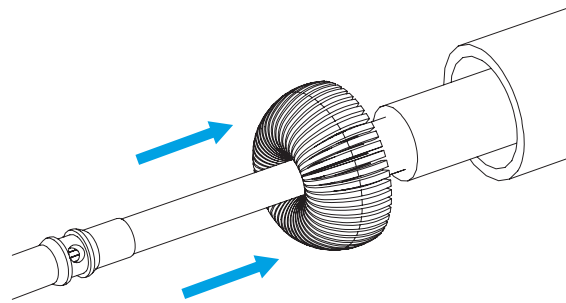

05 Insert the inner contact into the coax contact until You hear a click
Den inneren Kontakt in den Koaxialkontakt einführen, bis ein Klicken zu hören ist

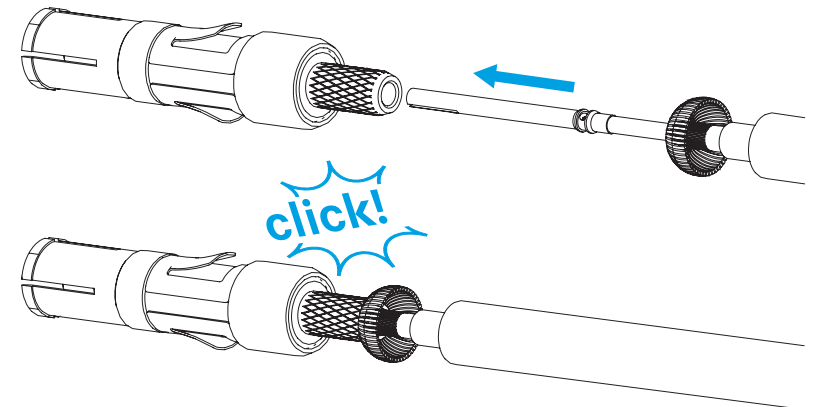

06 Cover the knurled surface with the shielding and push the crimp ferule forward
Den gerendelten Bereich mit Schirmgeflecht bedecken und die Crimphülse nach vorne schieben

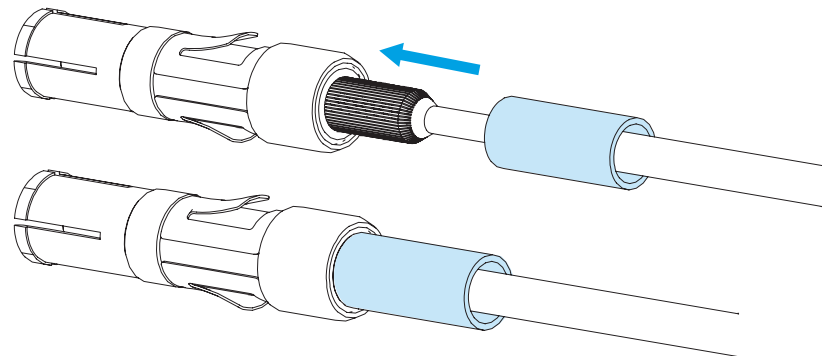

07 Put the crimping ferule into the crimp insert in shaft 2.67mm and Crimp the ferule
Die Crimphülse in Schacht 2.67mm, der Crimpzange, einlegen und die Hülse crimpen

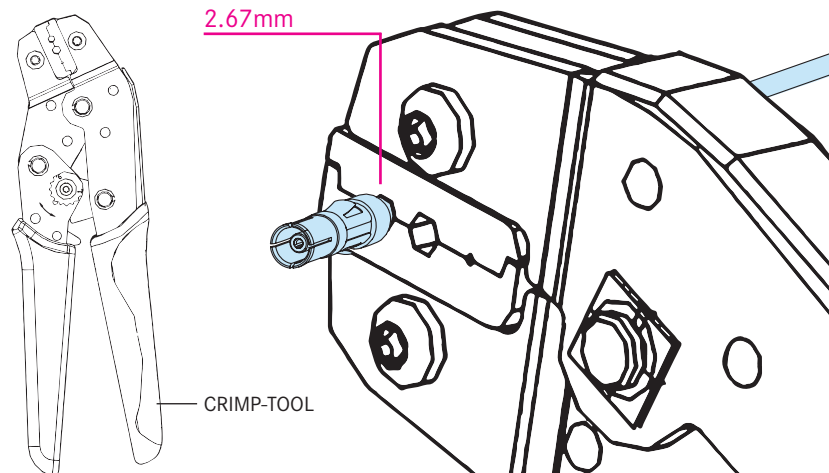

08 Assembly successfully accomplished
Montage erfolgreich durchgeführt

